



OHMEX

INSTRUMENTATION

SONARMITE v4.0

DFX dual beam

PORTABLE BLUETOOTH ECHO SOUNDER



Ohmex is a company formed to manufacture and distribute products designed by Lymetree Associates established in 1982 founded on technological innovation and design. The designer prides themselves on being the first to produce products in the field of instrumentation and software used within the Earth Science sectors. Achievements to date include DGM ,the first digital ground modelling software to run on a standard PC, SONARLITE, the first truly portable echo sounder, TIDALITE the first portable Tide Gauge, EDAS, Integrated tide and weather networked software for use by ports and harbours. SONARMITE the first portable Bluetooth echo sounder based on WinSTRUMENTATION - The integration of Instrumentation, Wireless networks and modern portable computer equipment.



Contents

INTRODUCTION.....	4
Is Dual Frequency required ?	5
Can mud thickness can be measured with Dual Frequency ?	5
Typical Use of the Equipment	5
Equipment Supplied.....	6
Accessories.....	7
INSTALLATION & USE	8
Switching the System On	8
Data Collection Techniques	8
Sound Velocity Settings	9
Reverse Voltage Protection	9
Weatherproofing	9
DEPTH TRANSDUCER.....	10
Transducer Mounting	10
Avoid Stressing Transducers	11
BLUETOOTH INTERFACE.....	12
BlueTooth ID/Password code.....	12
Bluetooth™ Serial Port Profile	12
Features	12
Bluetooth - actual range of the device.	13
Connecting to another Bluetooth™ PC/PDA.....	13
SERIAL CABLE INTERFACE.....	14
Typical Windows HyperTerminal settings.....	15
CONNECTIONS	16
'PC' or Computer connection.....	16
'Transducer' connection	16
APPENDIX.....	17
SonarMite Settings.....	17
Flash Memory	17
DFX version Commands	17
☺ (^H)elp.....	17

Memory Operations.....	17
☺ (^R)eset	17
☺ (^L)oad	18
☺ (^S)ave.....	18
General Operations.....	18
☺ (?) Query format	18
☺ (^F)ormat	19
☺ (^V)ersion.....	22
☺ (^I)d.....	22
☺ (^U)p	22
☺ (^D)own.....	22
☺ (^C)lear.....	22
☺ (^B).....	22
Transducer Specification.....	23
Transducer Dimensions.....	24
System Specification	24
WIRING DIAGRAMS.....	25

INTRODUCTION

The SonarMite Echo Sounder was the result of nearly two years research and development to further extend the boundaries of shallow water hydrographic surveying equipment. The introduction by Ohmex of the SonarMite, the worlds first truly portable echo sounder system, has been a hard act to follow and it remains the portable instrument of choice in many survey companies around the world. The release of the SonarMite DFX instrument marks the next stage introducing a series of equipment designed around the WinSTRUMENT concept using the latest portable computers integrated with new measurement technologies.

Throughout the Hydrographic world the term 'Black Box' has become a euphemism for a device that has a minimal user interface and normally requires connection to a PC to be of any use ! In most cases these boxes are a cut down version of a more conventional instrument without all the features of the full system. The SonarMite extends this idea of a rugged design and minimalist interface to produce a 'Blue Box' system where the user interface is provided by integrated software running on a portable computer connected via a Bluetooth link. The use of wireless technology enables the instrument to be waterproof and used in a hostile environment while the more sensitive computer features can be located in a more user friendly environment up to 100m away from the instrument.

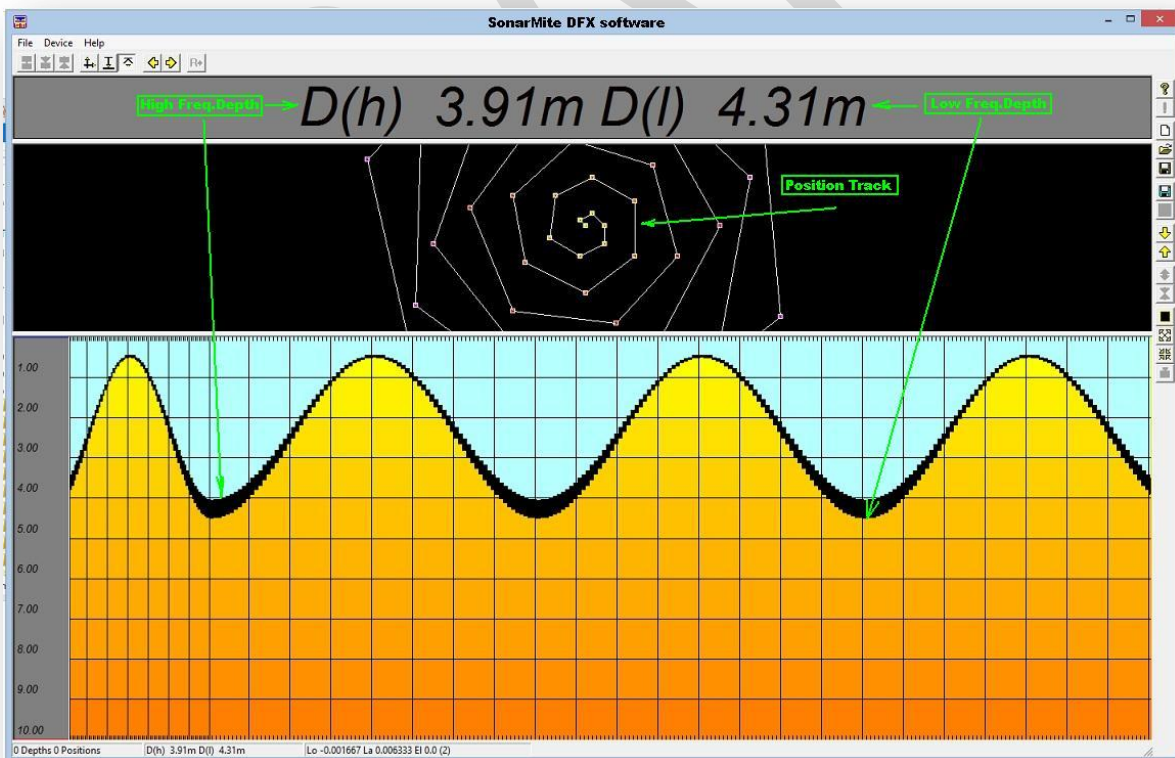

SonarMite DFX logging software

The SonarMite DFX instrument uses the same 'Smart' integrated transducer technology used in previous systems, in addition to highly reliable bottom tracking algorithms using DSP techniques the system also outputs a water temperature measurements with associated with every depth measurement made. The popular SonarW7 software has been updated to the latest Windows versions. Software for the 'front end' of the SonarMite is available to run on a wide range of devices from Pocket PCs through to the full range of desktop and Tablet systems running the Windows operating system.

Is Dual Frequency required ?

Dual frequency echo sounders were originally designed for use by sea going vessels to give reliable depths in deep water situations (low frequency) and more accurate navigation within shallow areas (high frequency). Low frequency is of little use in shallow hydrographic surveys

- Physical accuracy is outside IHO specifications
- Power consumption prohibits true portable use
- Minimum depth possible outside survey requirements

However, Dual Frequency measurements may be specified as part of a survey contract as it is a good gross check on high frequency performance (does not reflect from small objects in the water column) and it will indicate areas of soft bottom.

Can mud thickness can be measured with Dual Frequency ?

The residual difference between low and high frequency shown on an echogram gives the impression that mud thickness can be measured. In fact the trace does give an impression of soft sediment, however, in most sounders this is just the difference in reflected energy as a result of simple penetration of higher power low frequency signals plotted against the low power high frequency returns.

To measure mud thickness and avoid litigation on wrong results the surveyor should use equipment specifically designed for geophysical measurements such as a sub-bottom profiler, penetrometer, seismograph or a simple bottom sample grab.

Typical Use of the Equipment

The SonarMite Portable Echo Sounder has been designed to provide a portable instrument that provides the facilities of a 'professional' sounder at the cost and performance of a 'fish finder' device. It is important to recognize what the differences are between these two types of echo sounder. The 'fish finder' or leisure craft devices are primarily concerned with two functions, finding fish in the water column below the boat by sensing returns from their swim bladders and providing a bottom tracking/smoothing algorithm to detect minimum water depth below the

boats hull. Survey sounders are designed to provide a large number of pings with as little processing of the raw data as possible to define the bottom in as fine detail as possible. Of major concern in a survey sounder is a narrow beam width to prevent averaging of the returned signal.



200/30 KHz Active Transducer

The SonarMite uses Active Transducers, these are digital as opposed to analogue components and use microprocessors to synthesize transmitted frequencies and to interpret the return signals. The devices incorporate state of the art DSP and filtering techniques to reduce noise and improve depth tracking. These devices are supplied encapsulated in resin and have no serviceable parts. The connecting cable to the transducer carries only low DC voltage and digital I/O, none of the EMC problems associated with conventional analogue sonar devices apply.

To improve weatherproofing and to avoid connection problems the SonarMite has two connectors that provide all the I/O required by the device. One of the connectors also includes a return pin to enable the system to be 'turned on' by cable connection rather than using a switch. Cables to the device can be connected simultaneously (e.g. Transducer on port 1 and Serial Data Cable on Port 2).

Equipment Supplied

The **SonarMite DFX** is supplied as standard with the following list of equipment ...

- SonarMite DFX main processor unit c/w Bluetooth Antenna
- 'Smart' DF depth transducer c/w 5m cable and embedded processor
- Serial data lead
- IP68 rugged plastic Transit case
- SonarW7 post process/import/export software

Accessories

The following is a short list of accessories for the SonarMite DFX ...

- SonarMite DFX Windows Mobile PDA software
- SonarMite DFX Windows PC/Tablet software
- USB serial data lead
- Aluminium fitting to connect transducer to detail pole
- Portable internal NiMh battery pack and charger.



SonarMite DFX dual beam echo sounder

The SonarMite DFX is a compact, portable, low power system for use in shallow water hydrographic surveys, it's small size and low power requirements make the system easy to deploy and transport to remote or inaccessible sites. The SonarMite DFX is a dual beam echo sounder providing a wider range of solutions for surveyors working in shallow water hydrographic surveying.

INSTALLATION & USE

This chapter describes how the SonarMite Portable Echo Sounder would normally be installed and used. The typical way in which the device can be used for hydrographic surveying applications, is as a 'Dumb' echo sounder connected via a serial cable/Bluetooth Link to a PC or PDA running data logging and display software. Another option is to use both data streams with the serial output data for real time processing and the parallel Bluetooth output for graphic depth display.



Typical bow transducer mounting

Switching the System On

To turn the system on the user ensures the system is connected to a battery then connect the transducer to the 'Txr' connector on the front panel, the green LED alongside the Bluetooth antenna will then illuminate.

Data Collection Techniques

When not used as a 'Dumb' echo sounder in conjunction with a data logging package the SonarMite can be used in conjunction with the following data types to create full XYZ hydrographic data using the SonarW7 software package....

- Total Station XYZ data plus Time
- XYZ data from RTK GPS plus Time
- XY data from DGPS plus Tide plus Time

- Range and Bearing from hand held laser plus Tide plus Time
- Simple event marking past known position markers

The basis on which all data correlation is achieved is internal time base, so particularly when using the SonarMite with GPS data the data logger clock should be synchronized to GPS time (UTC).

Sound Velocity Settings

The SonarMite default Speed of Sound in Water(SoS) setting is 1500m/second, facilities to vary this have been provided in the calibration or in post processing. In practice this velocity value can vary due to several factors ...

- Water Temperature
- Water Salinity
- Water Turbidity

All of the above factors vary the density of the water in some way and effect the ‘time of flight’ of a pulse of ultrasound in water and hence the depth calculated from this time by the SonarMite. The user can either measure the speed of sound in water by taking velocity profiles using a dedicated velocity measuring device or can use the SonarMite static over a known depth to a flat, firm base and then compare the measured value with the known depth. The difference in Sound Velocity between warm fresh water and cold salt water is about +/-30m/Second which represents a change of depth of +/-2%, this must be viewed in context with typical depths of the survey, if a typical depth is 10m then the error could be about 20cm. **The Sound Velocity setting is the largest source of measurement error when care is not taken in setting it correctly.**

Reverse Voltage Protection

The SonarMite DFX is protected from reverse connection or direct short circuit by an internal diode and 1 Amp thermal fuse. If the fuse is tripped then the system will need to be disconnected for 1 minute for the fuse to cool down and reset itself.

Weatherproofing

The SonarMite has been designed to conform to the IP65 waterproofing standard, this benchmark describes equipment which can withstand a light spray of water from a hose for a short period of time, it does not imply the device is suitable for immersion in any depth of water or exposed to prolonged harsh weather conditions. The weatherproofing also assumes the connectors or cover caps are fully screwed on to their rubber sealing rings. The weatherproofing does not apply to certain components which are by definition not designed for outdoor use such as the D9 serial or USB cable connectors.

DEPTH TRANSDUCER

The SonarMite DFX system uses a ‘boat’ shaped transducer in a three bolt mount fitting for fixing to an outrigger of a light boat or more commonly in a temporary mounting using a survey detail pole. **The transducer includes a unique processor and is not the same device as the commercially available transducers.**

- Hydrodynamic shape provides vertical sound beam orientation
- Chemical and impact resistant plastic resin housing
- Designed to meet CE requirements
- Shielded piezoceramic element for noise free echo sounder display
- Standard minimum cable length: 5.0 m (16 feet)

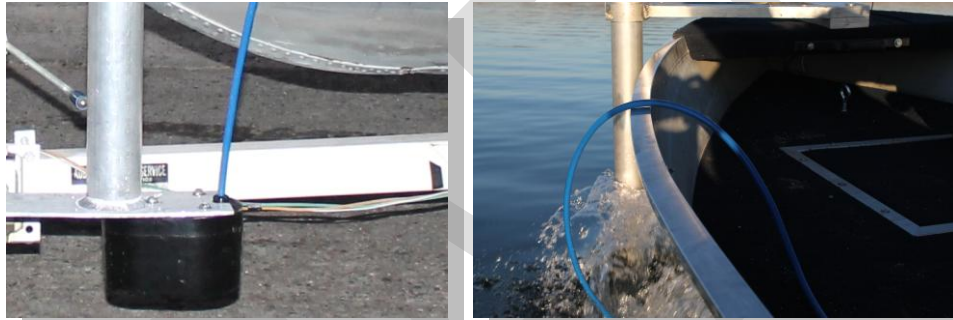

Transom Mounting Transducer

Transducer Mounting



Typical bow transducer mounting

When mounting the transducers the following points should be taken into consideration ...

- How near to the Metacentre of the boat is the transducer
- Is any turbulence generated around or in front of the transducer when moving
- Is the turbulence from the propellers in the field of view of the transducer

The only important consideration in mounting is that the transducer is always in the water and that the transducer does not represent an obstacle when the boat is used at higher speeds (i.e getting to the survey location). If at all possible mounting the transducer directly below the positioning antenna reduces the calculation of X/Y offsets to zero.

Example Transducer Mounting

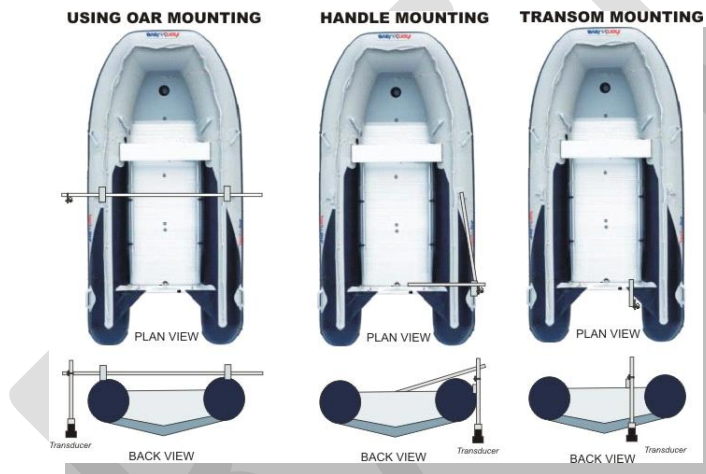

Typical small boat mounting

Avoid Stressing Transducers

The Active Transducers include piezoelectric elements which are embedded within a resin compound. If the user has to fabricate a custom mounting for the transducer (a very common requirement given the vast permutations of boats in which surveys are performed) avoid using a fixing technique that causes physical stress in the transducer body as this will change the resonant properties of the device and effect its depth measuring accuracy.

BLUETOOTH INTERFACE

The SonarMite deck box provides a fully compliant wireless Bluetooth™ Class 1 Master and Slave function via a simple UART or RS232 interface. The Bluetooth Wireless will provide connectivity to any device supporting either a UART or RS232 interface. The SonarMite Bluetooth Serial is compatible with all other device supporting Bluetooth™ SPP (Serial Port Protocol).

BlueTooth ID/Password code

In some instances the local Bluetooth interface may request a password/ID to set up pairing with the device, for DFX/SPX version devices the pin number is always set to ‘1234’ (numeric - one two three four).

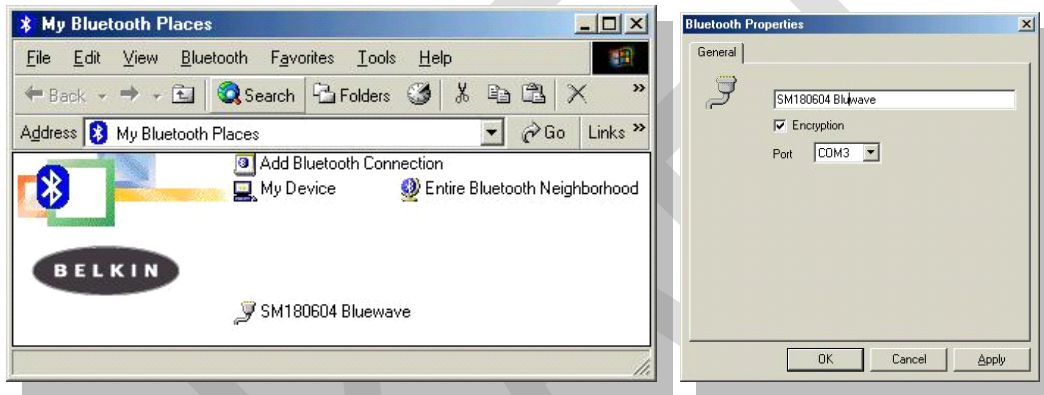

Typical PC Bluetooth software

Bluetooth™ Serial Port Profile

Bluetooth Serial provides either a Bluetooth™ slave or master connection fully supporting the (SPP) Serial Port Profile ...

Features

- Fully Bluetooth™ Class 1 v1.1 SPP compatible
- Wireless range of over 100m (330ft)
- Integrates with RS232 or UART systems.
- Small footprint
- Platform independent
- Various low power sleep modes
- SMA Antenna connection for direct antenna connection or coax

The SonarMite Bluetooth Serial Terminal encapsulates all of the Bluetooth™ protocols on a dual chip, providing a simple serial interface to the host, therefore removing any need for software drivers or experience in developing wireless technology

Bluetooth - actual range of the device.

The device uses Bluetooth class 1. The range will depend on the other Bluetooth™ device that it is connected to. It will also depend on the physical environment i.e. obstructive walls and the type of walls the signal will need to go through and on the antenna that is fitted. Assuming it is connected to a class 1 device then the maximum range should be between 50 and 150 meters.

Connecting to another Bluetooth™ PC/PDA

The Bluetooth Serial Terminal will connect to any Bluetooth™ enabled device supporting SPP. This can be in MASTER mode, where the terminal initiates the connection, or SLAVE mode, where the remote device initiates the connection. The method of connection will vary depending on the remote device. However, generally the other device will perform a four stage process.

- The remote device will “discover” other Bluetooth devices. The Bluetooth device will appear as “SMnnnnnn” (where nnnnnn is serial number).
- The remote device will need to “Pair” with the SonarMite Bluetooth. The pin number is then entered.
- The remote device will connect to the serial port service of the SonarMite Bluetooth Serial Terminal.
- A virtual “Outgoing” communications Comm port will then generally be created and the application can then talk over this port to any connection to the SonarMite Bluetooth Serial Terminal.
- **WHEN CONNECTED THE RED LED WILL ILLUMINATE AND FLASH CONTINUOUSLY**

SERIAL CABLE INTERFACE

In addition to Bluetooth on the DFX all SonarMites have a serial interface which can connect to a computer using RS232 protocol, this may also be provided by the USB serial interface cable available as an accessory. The default settings are ...

4800 Baud Rate 8 Bit 1 Stop Bit No Parity



Example Serial Cable



Example USB adaptor cable

Using the slower baud rate of 4800 allows the serial cable to be extended so that the computer can be up to 20m away from the echo sounder.

Communication with the SonarMite over any of the serial device 'com' ports can be achieved using a simple terminal communication program such as the 'Hyperterminal' program supplied with the Windows operating system. There are various other public domain packages such as Widcom or TTpro offering similar facilities to Hyperterminal. The popular SenaTerm program can run on Android devices and programmed with the SonarMite control codes.

Typical Windows HyperTerminal settings

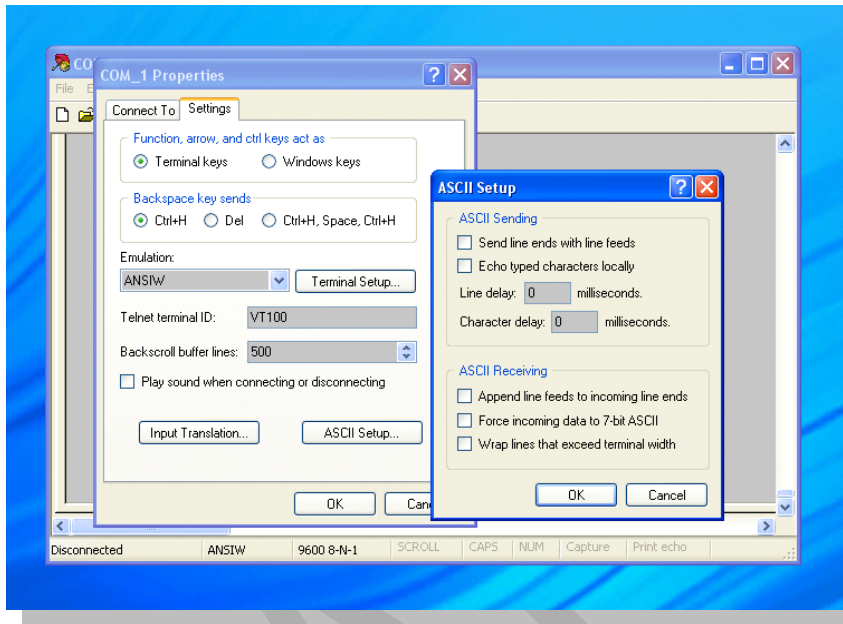

Hyperterminal ASCII settings

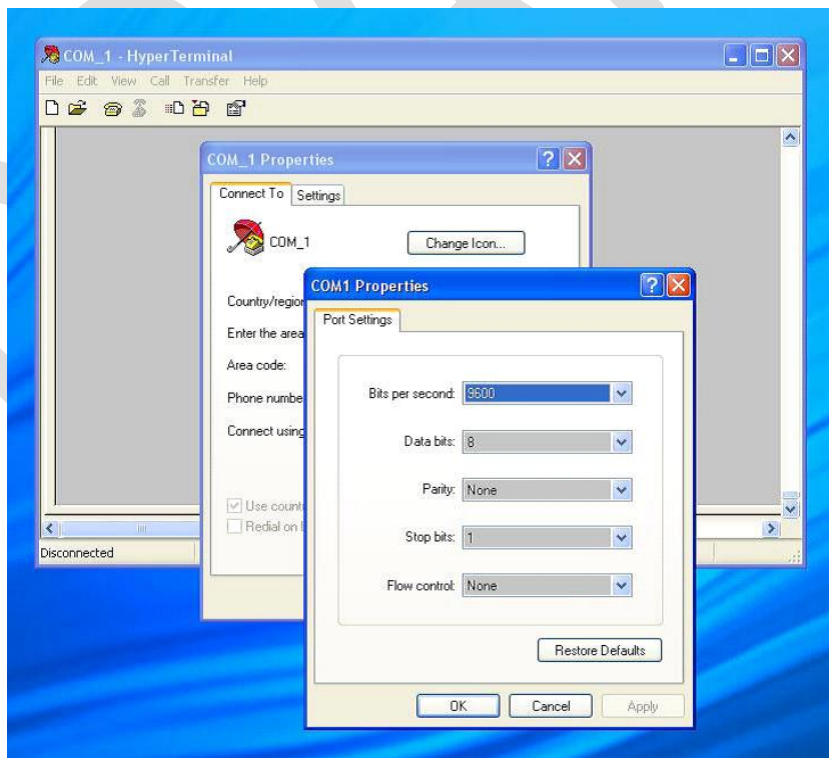

Hyperterminal Connection settings

CONNECTIONS

The only accessible connectors on the SonarMite are those on the front of the machine referred to as the 'Transducer or TXR' and 'Computer or PC' connections. **There are no user connections or serviceable parts within the SonarMite body itself.**

'PC' or Computer connection

This 6 way female connector is used to connect to either a PC serial connection or for an incoming message in the 'polled' mode connection.

'Transducer' connection

This 6 way male connector is used to connect to the SonarMite transducer, the same connection is also used for the battery charger connector.

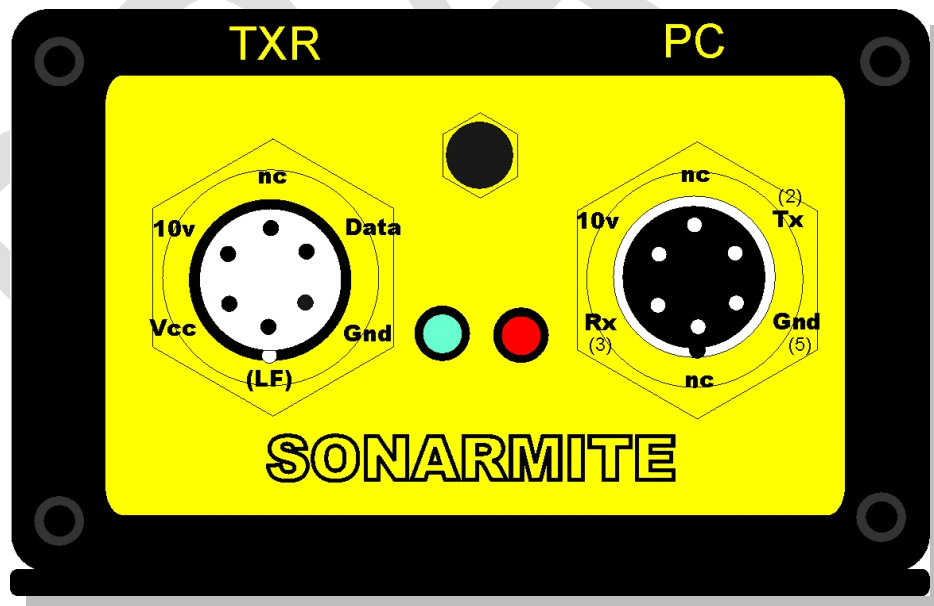

Transducer and Computer connections

APPENDIX

SonarMite Settings

The SonarMite when connected via Bluetooth to a serial communications program such as Hyperterminal has a basic set of simple dual character commands used to set the basic parameters of the instrument.

Flash Memory

The instrument contains an area of configuration data held within its semi-permanent FLASH memory area. On running the instrument this data is copied into the current working RAM area of the processor. Pressing any of the configuration command characters will only change the current active states enabling the user to sample output until the 'Save' command is used to store the current settings and make them the new defaults when the system is rebooted.

DFX version Commands

☺ (^H)elp

Pressing ^H (Contol H) will display the following help information as an aid memoir to the available commands...

`^Help,Format,Version,Id,Save,[Reset,Load,U/Dsos]`

Commands shown in parenthesis [] are only available in the **SYS>** format.

Memory Operations

☺ (^R)eset

Pressing ^R (Contol R) will reset the SonarMite to its default values, these values are saved in Flash memory and set in current working RAM memory (**only available in the SYS> output mode**).

☺ (^L)oad

Pressing ^L (Contol L) will reload the Flash memory into the current working memory. (**only available in the SYS> output mode**).

☺ (^S)ave

Pressing ^S (Contol S) will save the current working memory area to Flash memory to become the system settings on reboot.

General Operations

☺ (?) Query format

Pressing ? will reply with current output formats as below ...

```
SonarMite MFX
Simple ASCII
DBT NMEA
DPT NMEA
Odom SBT
DESO 25
Raw transducer data
System
```

☺ (^F)ormat

Pressing ^F (Contol F) will toggle the output formats as below ...

Format 0 Format = MFX SonarMite

```
1 28.55 29.25 15.15 10.9 7
1 28.36 28.96 15.15 10.8 7
1 28.18 28.72 15.15 10.8 7
1 28.05 28.48 15.15 10.8 7
1 27.90 28.21 15.15 10.9 7
1 27.73 28.06 15.15 10.9 7
```

Example Standard Sonamite MFX Output

Output Parameters

Output message is ID integer + six numeric ASCII parameters, floating format, space delimited as ...

id hdepth ldepth wtemp battery flags<cr><lf>

where ...

id = The id number of the instrument (0..7)
hdepth = current hi freq measured depth (m)
ldepth = current lo freq measured depth (m)
wtemp = current water temperature (deg.C)
battery = current battery condition (v)
flags = binary data seen flags 1=Hi, 2=Lo, 4=Wt (e.g. 7=all seen)

Please note that if no transducer is seen or out of water then the output will appear as a string of ID+5 nulls at 1 second timeouts, in normal operation the five numbers are reported at 0.5 second intervals.

Format 1 Simple ASCII mode (e.g. 18.41 18.52 <cr><lf>)

```
18.41 17.92
18.45 17.94
18.48 17.96
18.54 18.00
18.60 18.01
18.65 18.05
18.69 18.09
```

Example Simple ASCII Output

Format 2 DBT NMEA mode (e.g. \$SMDBT,5.94,f,1.81,M,,*67)

```
$SLDBT,48.6,f,14.83,M,,*76
$SHDBT,50.2,f,15.31,M,,*77
$SLDBT,48.7,f,14.86,M,,*72
$SHDBT,50.4,f,15.37,M,,*77
$SLDBT,48.9,f,14.90,M,,*7B
$SHDBT,50.6,f,15.43,M,,*76
$SLDBT,49.0,f,14.94,M,,*77
$SHDBT,50.8,f,15.48,M,,*73
$SLDBT,49.1,f,14.96,M,,*74
$SHDBT,51.0,f,15.56,M,,*75
$SLDBT,49.2,f,15.00,M,,*79
```

Example NMEA DBT Output

Format 3 DPT NMEA mode (e.g. \$SMDPT,1.81,0.0*66)

```
$SLDPT,16.68,0.0*72
$SHDPT,17.53,0.0*7F
$SLDPT,16.66,0.0*7C
$SHDPT,17.55,0.0*79
$SLDPT,16.65,0.0*7F
$SHDPT,17.53,0.0*7F
$SLDPT,16.63,0.0*79
```

Example NMEA DPT Output

Format 4 Odom SBT mode (e.g. et 47)

```
et H 2493
et L 2379
et H 2516
et L 2392
et H 2572
et L 2430
et H 2583
```

Example Odom Output

Format 5 Deso 25 mode (e.g. DA 0.48 m)

```
DA 32.08 m
DB 31.83 m
DA 32.04 m
DB 31.81 m
DA 32.00 m
DB 31.80 m
DA 31.96 m
DB 31.76 m
DA 31.93 m
DB 31.72 m
DA 31.91 m
DB 31.68 m
```

Example Deso Output

Format 6 Raw txr Data mode (e.g. any text line in here 0.48 116)

```
$$DXDR,D,31.06,M,XDHI,D,30.35,M,XDLO,C,15.15,C,WTHI*76
$$DXDR,D,31.03,M,XDHI,D,30.35,M,XDLO,C,15.15,C,WTHI*73
$$DXDR,D,30.99,M,XDHI,D,30.33,M,XDLO,C,15.15,C,WTHI*77
$$DXDR,D,30.97,M,XDHI,D,30.31,M,XDLO,C,15.15,C,WTHI*7B
$$DXDR,D,30.95,M,XDHI,D,30.30,M,XDLO,C,15.15,C,WTHI*78
$$DXDR,D,30.95,M,XDHI,D,30.28,M,XDLO,C,15.15,C,WTHI*71
$$DXDR,D,30.95,M,XDHI,D,30.28,M,XDLO,C,15.15,C,WTHI*71
$$DXDR,D,30.95,M,XDHI,D,30.28,M,XDLO,C,15.15,C,WTHI*71
```

Example Raw Data Output

Format 7 Old SonarMite format (e.g. 1 1.88 12.7 128 20)

```
1 30.16 0 0 0 10.9 100 7
1 29.43 0 0 0 10.9 100 7
1 29.23 0 0 0 10.9 100 7
1 29.04 0 0 0 10.9 100 7
1 28.89 0 0 0 10.9 100 7
1 28.81 0 0 0 10.8 100 7
1 28.68 0 0 0 10.8 100 7
1 28.55 0 0 0 10.8 100 7
```

Example Old SonarMite Output

Format 8 mode used for system settings

```
SYS> 1 29.68 29.79 15.1 9 9 0 1500 11 7
SYS> 1 29.70 29.81 15.1 9 9 0 1500 11 7
SYS> 0 29.71 29.83 15.1 9 9 0 1500 11 7
SYS> 1 29.73 29.85 15.1 9 9 0 1500 11 7
SYS> 1 29.75 29.88 15.1 9 9 0 1500 11 7
```

Example System Output

☺ (^V)ersion

Display the current firmware version number

nSonarMite v4.01(c)2013 LYMTREE

☺ (^I)d

Toggle the ID number of the instrument. This function is intended for use in multiple transducer systems running in polled mode.

☺ (^U)p

Increase the sound velocity setting for dense cold water (only available in the SYS> output mode).

This is a dangerous function and will change calibration values if saved

☺ (^D)own

Decrease the sound velocity setting for lighter fresh/warm water (only available in the SYS> output mode).

This is a dangerous function and will change calibration values if saved

☺ (^C)lear

Reset output to format 0. (used by external programs).

☺ (^B)

Reset output to format 0. (used by external programs).

Transducer Specification

Technical Data—30 kHz-D

TVR in dB re 1 μ Pa/Volt at 1 m

RVR in dB re 1 Volt/ μ Pa

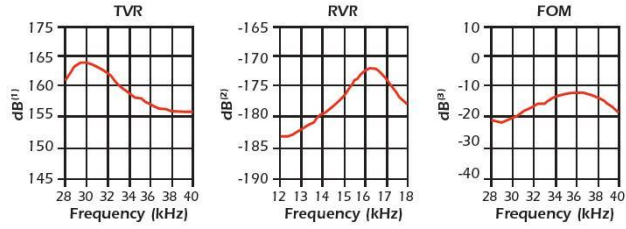

Directivity Pattern—30 kHz-D

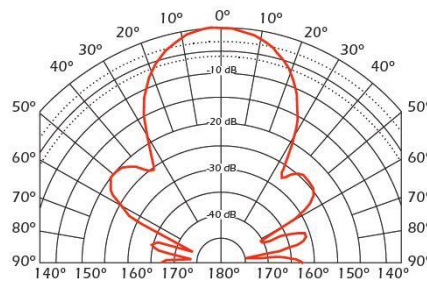

30KHz Beam Pattern

Technical Data—200 kHz-BC1q

TVR in dB re 1 μ Pa/Volt at 1 m

RVR in dB re 1 Volt/ μ Pa

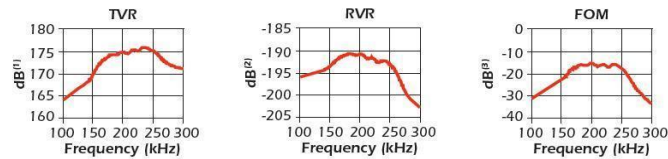

Directivity Pattern—200 kHz-BC1q

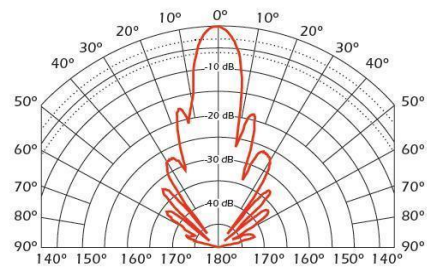

200KHz Beam Pattern

Transducer Dimensions

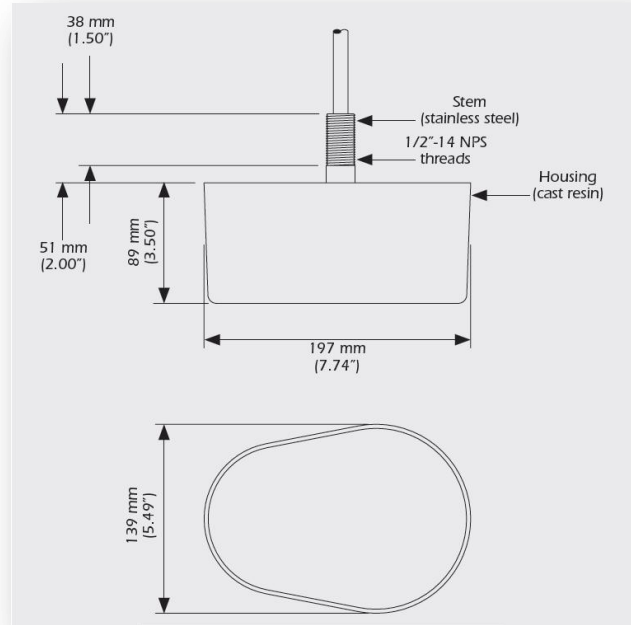

200/30KHz Transducer Body

System Specification

Transducer Hi Frequency	200 KHz Active Transducer
Beam Spread	8 to 10 Degrees
Depth Range	0.30m to 75.00m (Software limited)
Accuracy	+/-0.03m (RMS)
Weight	2.4 Kg
Transducer Lo Frequency	30 KHz Active Transducer
Beam Spread	8 to 30 Degrees
Depth Range	1.2m to 200.0m (Software limited)
Accuracy	+/-0.130m (RMS)
Weight	2.4 Kg
Data Output Range	2Hz
Ultrasonic Ping Rate	3 to 6 Hz (Depth dependent)
Power Supply	9 to 25vDC (12vDC typical)
Power Consumption	150ma to 200ma (temp dependent)
Data Format	RS232C 4800 baud 8 bit 1 stop bit No parity
Operating Temperature	0 to 40 degree Centigrade
Overall Dimensions	100w x 220h x 45d (mm)
Weight	0.75Kg

WIRING DIAGRAMS

